



## Fitting Instructions

### PTP140020008 – Remote Thermostat

#### Kit Includes

- 1 x PRRT Remote Thermostat
- 3 x Silicon Hoses
- 5 x Hose Clips
- 1 x Link pipe
- 1 x Thermostat blank

The following instructions are a simple guide to the fitting procedure of the PTP Bypass hose; this hose is specifically designed to fit either the S1 or S2 Elise.

- Firstly, the 2 rear under trays need to both be removed to enable the cooling system to be drained, if you're unsure of this procedure please refer to the workshop manual for your car.
- Drain the coolant system, following the recommended procedure. Please be careful not to let any coolant escape into your domestic drainage system.
- Next the thermostat needs to be replaced with the thermostat blanking plate; this is a very important step to take, as the car will over heat if it has 2 thermostats fitted. See fig 1 below. Ignore the inspection part though, as this doesn't apply to the blanking plate

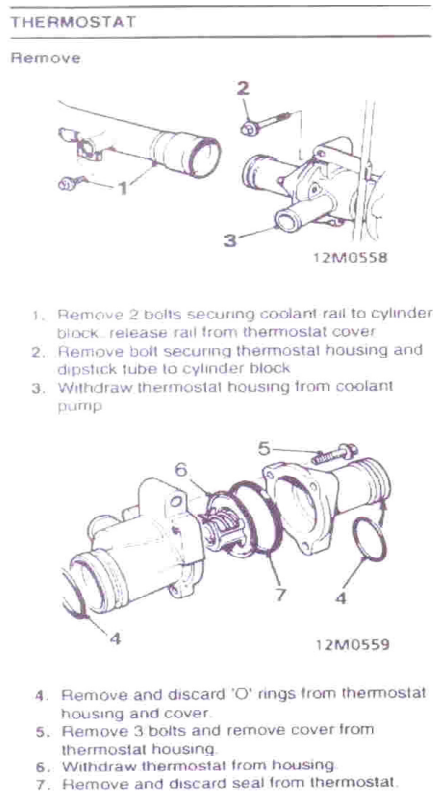

Fig 1.

#### Inspection

1. Test thermostat using thermostat test equipment, renew thermostat if necessary
2. Thermostat open = 88° C  
Starts to open = 85° to 91° C  
Fully open = 100° C

#### Refit

1. Clean thermostat housing, cover and sealing faces
2. Lubricate new 'O' rings with silicone grease and fit to thermostat housing and cover.
3. Fit a new seal to thermostat.
4. Align and fit thermostat to shoulder in thermostat housing
5. Fit cover to thermostat housing, fit and tighten bolts to 8 Nm.



**CAUTION:** Torque figure must not be exceeded.

6. Fit thermostat housing to coolant pump, align dipstick tube bracket, fit and tighten bolt to 10 Nm.
7. Connect coolant rail to thermostat cover
8. Align coolant rail to cylinder block, fit and tighten bolts to 25 Nm.

- Next you will need to take the existing water pipes off the engine, the first one is the top hose, and this is fitted to the water elbow, on the rear N/S corner of the cylinder head.
- Now remove the hose that connects to the engine rail, situated on the N/S of the engine (fig 2).

Fig 2

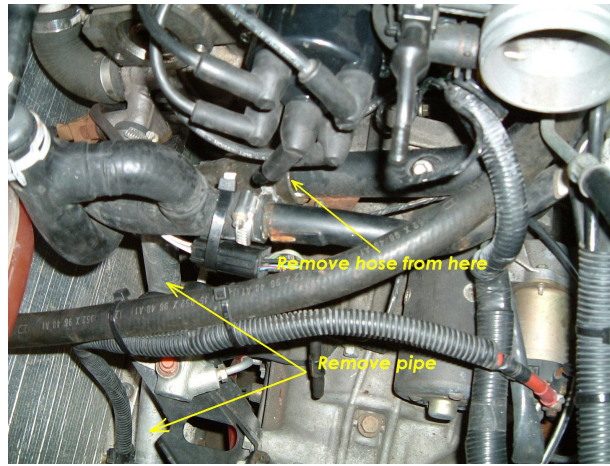

- Once these are removed, you should have on the floor a set of hoses as shown in fig 3. Now you need to make up the silicon hose set, fig 4 shows the kit, and fig 5 shows the assembled item.



Fig 3



Fig 4

Fig 5

- Fig 6 shows the difference in the hoses that you have, this will help you to understand where it is going to fit.
- Fit the new hose set moving the silicon hoses on the thermostat housing to suit
- Now tighten all the clips supplied, it is now ready to re-fill with coolant. Please follow the correct procedure for filling and bleeding the coolant system.
- Check all hose fitting for any leaks, if you're satisfied that there are non, re-fit the under trays, again following the correct procedure.

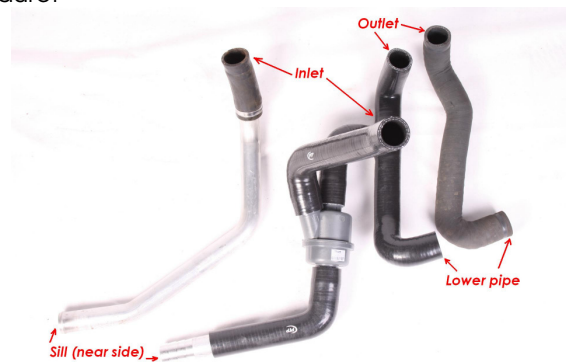

Fig 6